

# KENWOOD

## KRC-22

---

CASSETTE RECEIVER

### INSTRUCTION MANUAL

RADIO-CASSETTE

### MODE D'EMPLOI

RADIO CASETE

### MANUAL DE INSTRUCCIONES

RÁDIO CASSETE

### MANUAL DE INSTRUÇÕES

KENWOOD CORPORATION

**Take the time to read through this instruction manual. Familiarity with installation and operation procedures will help you obtain the best performance from your new cassette receiver.**

#### **For your records**

Record the serial number, found on the back of the unit, in the spaces designated on the warranty card, and in the space provided below. Refer to the model and serial numbers whenever you call upon your KENWOOD dealer for information or service on the product.

Model KRC-22 Serial number \_\_\_\_\_

# Safety precautions

English

## **▲WARNING**

### **Take the following precautions to prevent fire and avoid personal injury:**

- Press in the faceplate until it is firmly locked to the main unit to prevent it from being detached in an accident.
- When extending the ignition cable, battery cable, or ground cable, use 0.75mm<sup>2</sup> (AWG18) or larger automotive grade cable to avoid cable deterioration or damage to the covering.
- Check that no metal objects (coins, tools, etc.) are left inside the unit to avoid short circuits.
- If you smell or see smoke, turn the power off immediately and consult your Kenwood dealer.
- To prevent fire when the ignition cable (Red) or battery cable (Yellow) is short-circuited by coming into contact with the vehicle chassis (ground), only connect the power supply after making the fuse box connections.

## **▲CAUTION**

### **Take the following precautions to keep the unit in proper working order.**

- Be sure the unit is connected to a 12V DC power supply with a negative ground connection.
- Do not open the top or bottom cover.
- Do not install the unit in places it is exposed to direct sunlight, high heat or humidity, water may splash over it, or dust exists.
- Do not store the detached faceplate or faceplate storage case in places it is exposed to direct sunlight or high heat.
- Do not splash water on the faceplate.
- The faceplate is a precision piece of equipment that contains sensitive parts. Do not subject it to excessive shock.
- Do not touch the terminals of the faceplate or the unit.

- If you need to replace the fuse, make sure the new fuse is of the same type and rating. Using a fuse of a different type or rating may damage your unit. The fuse rating is normally shown on the fuse and fuse box.
- If you need to replace the fuse, unplug the wiring harness before replacing the fuse to prevent short circuits.
- If the car ignition does not have an ACC position, the ignition cable must be connected to a power supply source that can be turned on and off with the ignition key. If the ignition cable, like the battery cable, is connected to a power supply that always provides voltage, the battery may go flat.
- Check that no unconnected cables or connectors are touching the car body. Do not remove caps from unconnected cables or connectors to prevent short circuits.
- After installation, check that the brake lamps, wipers, and wipers work properly.
- Insulate unconnected ends of cords with vinyl tape or similar.

## **FCC WARNING**

- This equipment may generate or use radio frequency energy. Changes or modifications to this equipment may cause harmful interference unless the modifications are expressly approved in the instruction manual. The user could lose the authority to operate this equipment if an unauthorized change or modification is made.

**NOTE**

- After the unit is installed or the automobile battery has been replaced, be sure to press the reset button before using the unit. Press the reset button if the unit malfunctions. Contact your Kenwood dealer if the unit continues to malfunction even after the reset button has been pressed.

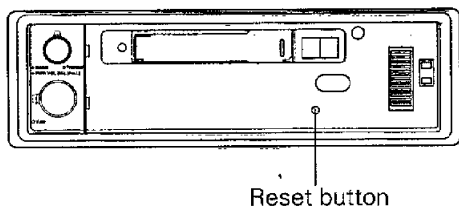

- The faceplate can be removed to prevent theft. When it is installed, align the unit protrusions with the depressions in the faceplate and press the right side of the faceplate until it locks.

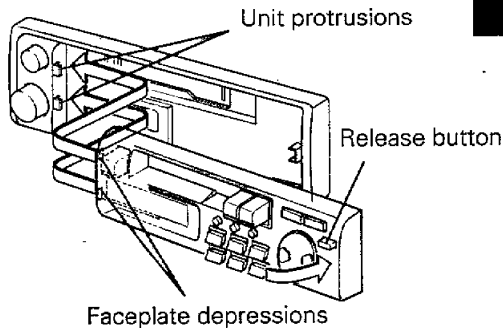

# Care and Maintenance

**NOTE**

- If you have difficulty in installing this unit in your vehicle, contact your Kenwood dealer.

### Cleaning the unit

- If the front panel is dirty, wipe it clean with a silicon cloth or soft dry cloth with the power off.

**CAUTION**

Do not use hard cloths or paint thinner, alcohol, or other volatile solvents. These may damage external surfaces or remove indicator characters.

### Cleaning the faceplate terminal

- If the faceplate terminal or mount faceplate terminal becomes dirty, wipe it clean with a soft dry cloth.

### Be careful with your tapes.

- Before loading a cassette, take up any slack tape, by turning one of the spools with a pencil. Loading a slack tape can cause tape to tangle around the capstan and pinch roller and other problems.
- Do not use any deformed cassettes or cassettes with labels coming off, or the unit may fail.
- Do not leave cassettes exposed to high heat (for example, on the dashboard where it is exposed to direct sunlight, or near heater outlets). This can deform the cassette shell.
- Avoid long cassettes, such as 100-minute tapes. The tape is thin and easily tangled around the pinch roller or other parts.
- If you do not listen to your tape, remove it from the unit and store it safely. If a cassette is left in for a long time, the tape can stick to the tape head, causing failure.

# Operations

English

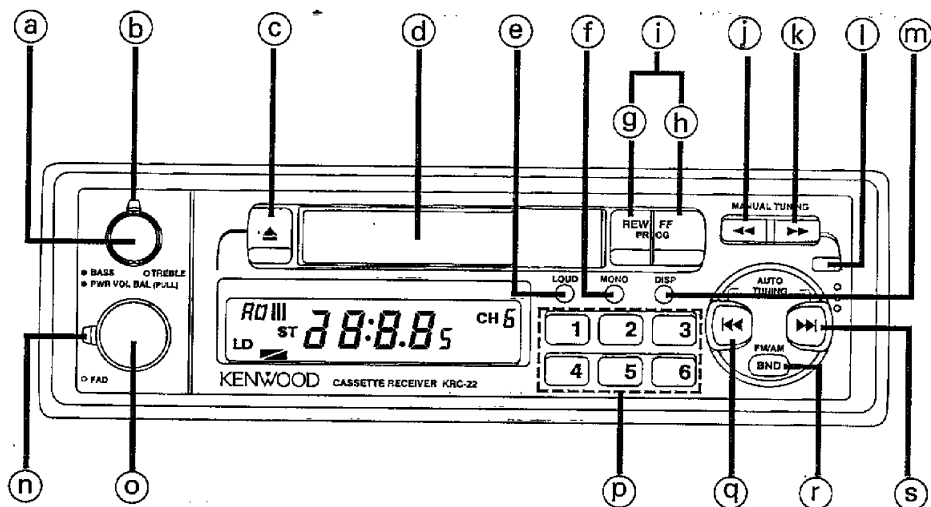

## All mode

### Power ON/OFF

Turn the (a) knob to the right to turn the power ON. Turn the (a) knob all the way to the left, to turn the power OFF.

### Volume

Turn the (d) knob to adjust the volume.

### Balance

Pull out the (c) knob and turn it to adjust the balance.

### Fader

When four speakers are connected, turn the (l) knob to adjust the fader effect of the front and rear speakers.

### Treble

Turn the (a) knob to adjust the treble setting.

### Bass

Turn the (b) knob to adjust the bass setting.

### Loudness

Press the (e) LOUD button to emphasize the high and low sounds. The LD indicator lights when the loudness function is set ON.

### Clock display

Press the (m) DISP button to turn the clock display ON and OFF.

### Setting the clock

If the (m) DISP button is pressed more than two seconds, the time display flashes and the time adjustment mode is set. Press the (i) ◀◀ or (h) ▶▶ buttons while the time display flashes to adjust the time. Press the (m) DISP button again to cancel the time adjustment mode.

### Theft deterrent faceplate

Press the (f) button to remove the faceplate.

## **Tuner mode** *Operate the tuner mode when the cassette tape is removed.*

### **Band select**

Each time the **Ⓞ** BND button is pressed, the reception band switches from FM I → FM II → FM III → AMI → AMII. (The selected band is shown on the display.)  
The ST indicator lights if a stereo broadcast is received.

### **Auto seek tuning**

Press the **Ⓞ**◀ button to perform auto seek tuning to the lower frequency stations.  
Press the **Ⓞ**▶ button to perform auto seek tuning to the higher frequency stations.

### **Manual tuning**

Press the **Ⓞ**◀ button to change one station at a time to the lower frequency stations.  
Press the **Ⓞ**▶ button to change one station at a time to the higher frequency stations.

### **Station preset memory**

1. The desired frequencies and stations are received.
2. If any **Ⓞ** button from 1 to 6 is pressed more than two seconds, the button number will be displayed on the display and the station will be stored in memory. A total of six stations can be stored in memory for each reception band.

### **Mono reception**

Monaural reception is set if the **Ⓞ** button is pressed when the stereo broadcast reception sensitivity is poor. The ST indicator goes off during monaural reception and the random noise can be reduced. If the **Ⓞ** button is pressed again, the stereo reception mode is set and the ST indicator lights.

## **Tape mode**

### **To play a cassette**

Set the side of the cassette where the tape can be seen on the right side, insert it in the cassette door **Ⓞ** and the tape playback will start.

### **To fast-forward**

Press the **Ⓞ**FF button to start and the fast-forward operation will start.  
Press the **Ⓞ**PROG button to stop the fast-forward operation.

### **To rewind**

Press the **Ⓞ**REW button and the rewind operation will start.  
Press the **Ⓞ**PROG button to stop the rewind operation.

### **To change sides**

Press the **Ⓞ**PROG button during tape playback to reverse the playback.

### **To eject**

Press the **Ⓞ**▲ button to eject the tape cassette.

## **▲CAUTION**

Always turn the unit power OFF or the key switch from ACC to OFF before removing the faceplate. Always eject the cassette before removing the faceplate.

# Installations

## Accessories

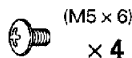
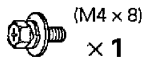
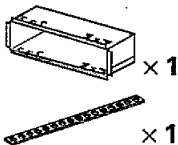
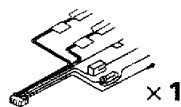

## Connection

1. Remove the ignition key and disconnect the negative (-) terminal of the battery to prevent short circuits.
2. Connect the Input and output cables of the units.
3. Connect the speaker cables of the wiring harness.
4. Connect the ground cable, battery cable, and ignition cable of the wiring harness in the order listed.
5. Connect the wiring harness connectors to the unit.
6. Install the unit in the car.
7. Connect the negative (-) terminal of the battery.
8. Press the Reset button.

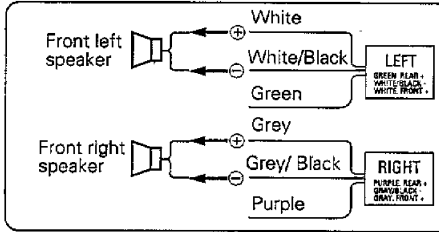
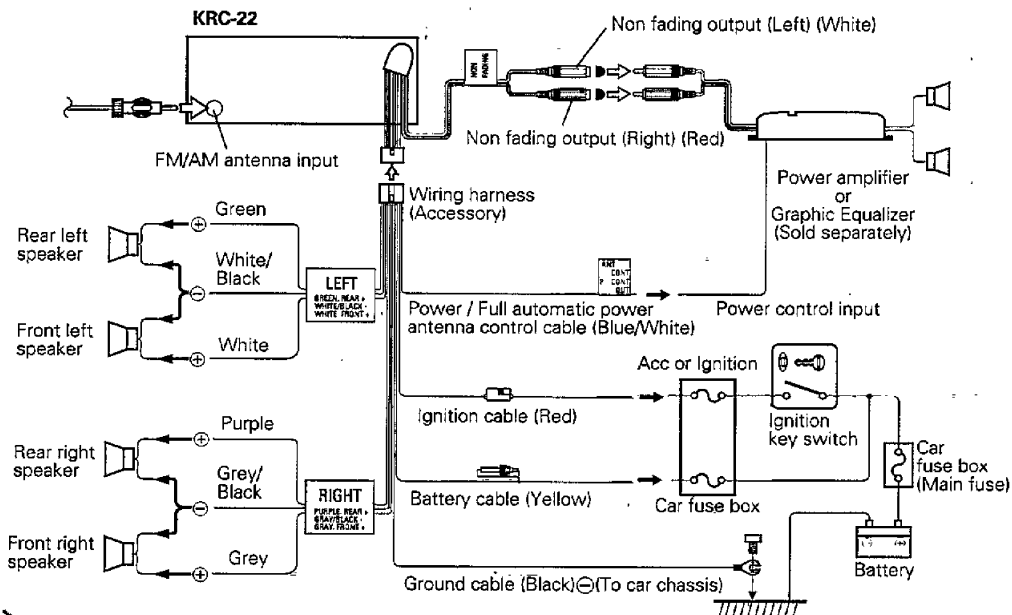

### CAUTION

When two speakers are connected to the system, be sure to connect both of them to the front output or rear output. In other words, do not connect the positive connector of the left speaker to the front output and the negative connector to the rear output.

# Installation

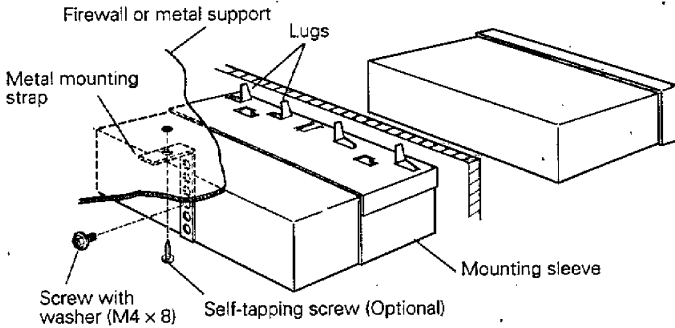

1. Insert the unit until the tab locks securely into the Mounting sleeve.
2. Attach the Mounting sleeve to the chassis by bending its lugs with a screwdriver.

# To remove the unit

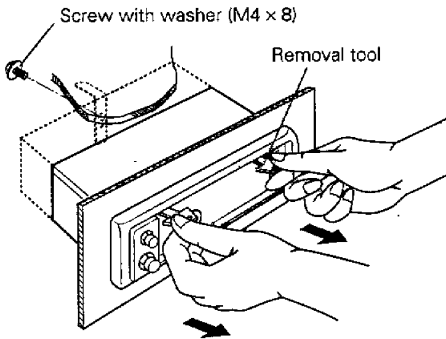

1. Remove the Screws with washer (M4 x 8) holding on the back panel.
2. Insert the removal tools deep into the slots of the unit.
3. Take the set out by hand, being careful not to drop it.

# To install in the Japanese car

1. Remove the escutcheon:

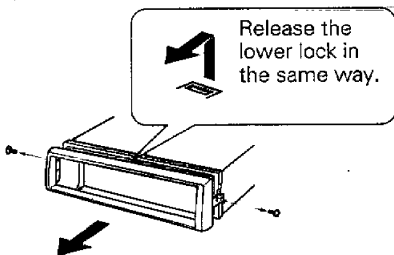

2. Fit the Machine screws (M5 x 6) (accessories) into the appropriate (two) holes in the car bracket.

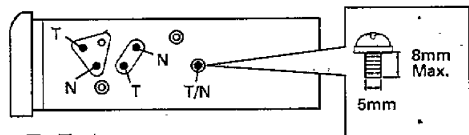

T : Toyota car  
N : Nissan car

# Specifications

English

## **FM Tuner Section**

Frequency Range (200 kHz space) .....	87.5 MHz ~ 107.9 MHz
Usable Sensitivity (S/N : 30 dB) .....	9.3 dBf (0.8 $\mu$ V/75 ohms)
Quieting Sensitivity (S/N : 50 dB) .....	15.2 dBf (1.6 $\mu$ V/75 ohms)
Frequency Response ( $\pm$ 3.0 dB) .....	30.Hz ~ 15 kHz
Signal to Noise Ratio .....	73 dB
Selectivity ( $\pm$ 400 kHz) .....	80 dB
Image Response Ratio .....	70 dB
IF Response Ratio .....	100 dB
Stereo Separation (1 kHz) .....	40 dB

## **AM Tuner Section**

Frequency Range (10 kHz space) .....	530 kHz ~ 1710 kHz
Usable Sensitivity (S/N : 20 dB) .....	28 dB $\mu$ (30 $\mu$ V)

## **Cassette Deck Section**

Tape Speed .....	4.76 cm/sec.
Wow & Flutter (WRMS) .....	1.2 %
Frequency Response ( $\pm$ 3 dB) .....	30 Hz ~ 14 kHz (120 $\mu$ s)
Separation (1 kHz) .....	43 dB
Signal to Noise Ratio .....	58 dB

## **Audio Section**

Maximum Output Power .....	25 W $\times$ 2 or 15W $\times$ 4
Output Power (1%THD, 30 Hz ~ 20 kHz, 4 ohms) .....	15 W $\times$ 2
Tone Action .....	Bass: 100 Hz $\pm$ 10 dB Treble: 10 kHz $\pm$ 10 dB
Preout Level/Load .....	1000 mV/10 kohms

## **General**

Operating Voltage .....	14.4 V (11 ~ 16 V allowable)
Current Consumption .....	5.2 A at Rated Power
Installation Size (W x H x D) .....	182 $\times$ 53 $\times$ 162 mm (7-3/16 $\times$ 2-1/16 $\times$ 6-3/8 in.)
Weight .....	1.6 kg (3.7 lb)

Specifications subject to change without notice.



KENWOOD